

Application of Distributed Photovoltaic Power Generation Systems on Rural Roofs in Rural Tourism

Pan Chang, Jing Qu, Ran Luan
Xi'an Kedagaoxin University, Xi'an, China

Abstract

Comprehensive rural revitalization represents a central goal of China's "Three Rural" work. In the process of promoting rural revitalization, it is necessary to balance the dual requirements of economic development and ecological environmental protection. Rural tourism can effectively revitalize idle rural resources, drive the development of rural industries, and help farmers increase their income. The construction of distributed photovoltaic (PV) power generation systems on rural rooftops can effectively solve problems such as energy pollution and electricity shortages in rural areas. This paper discusses the application of rural rooftop distributed PV power generation systems in rural tourism, analyzes the application value and practical pathways of this model, and provides a reference for sustainable rural development.

Keywords

Distributed Photovoltaic Generation Systems; Rural Tourism; Rural Rooftops.

1. Introduction

Realizing the comprehensive revitalization of rural areas serves as both the directional guide and the ultimate goal of China's work concerning agriculture, rural areas, and farmers. This endeavor holds great practical significance for China's efforts to build a modern socialist country in an all-round way. Numerous practices-such as those in Aba County of Sichuan Province, Azheke Village of Yunnan Province, and Yuanjia Village of Shaanxi Province-demonstrate that the development of rural tourism can rapidly drive the upgrading of rural industries, the aggregation of rural talents, and the preservation of rural culture, thereby effectively promoting rural revitalization. However, the rapid development of rural industries must be based on a certain level of energy consumption. Traditional fossil energy sources tend to aggravate carbon emissions and ecological pressures in rural areas, which runs counter to the goal of rural ecological revitalization. Therefore, it is urgent to seek coordination and unity between economic development and environmental protection.

In recent years, in order to solve the problems of rural economic development, clean energy utilization, and livelihood security, China has invested substantial financial support and implemented major measures such as clean energy promotion, agricultural power grid transformation, and clean heating in rural areas [1]. In particular, distributed PV systems have become a breakthrough and focal point for building a new power system in rural areas and enabling the low-carbon transformation of the energy system. This is due to their abundant development resources, low difficulty of development and construction, remarkable energy conservation and environmental protection benefits, and strong adaptability to rural building rooftops and idle land [2]. These systems provide a solution to the energy problems arising from the upgrading of rural tourism. Based on the actual needs of rural tourism development under the background of rural revitalization, this paper explores the application pathways and application value of distributed PV power generation systems in rural tourism scenarios, aiming to provide useful references for the transformation of electricity and energy in rural areas and the green development of rural tourism.

2. Feasibility of Applying Distributed Photovoltaic Power Generation Systems on Rural Roofs in Rural Tourism

2.1 Significant Policy Support

In January 2025, the National Energy Administration of China issued the Measures for the Administration of Distributed Photovoltaic Power Generation Development and Construction, further encouraging and supporting the development, construction, and operation of distributed PV power generation projects. According to the "Report on the List of Renewable Energy Power Generation Subsidy Projects" announced by the State Grid Corporation of China, distributed PV power generation projects can enjoy corresponding national power generation subsidy policies, and the income of such projects is guaranteed at the policy level. At the same time, provinces and municipalities such as Zhejiang, Hunan, Shanxi, Shanghai, and Beijing have also introduced favorable policies, including PV power generation subsidies. From project filing and grid connection to investment subsidies, clear support plans have been provided, which has further mobilized the enthusiasm of development and operation entities.

Shaanxi Province has launched the "PV+" rural revitalization demonstration project. It proposes that each township in the province should identify one administrative village and select either the PV or PV-heating project construction mode, with each village having a construction capacity of approximately 2 megawatts. By the end of the year, about 1,000 whole-village rooftop distributed PV and heating demonstration projects, with a total capacity of roughly 2 million kilowatts, will be completed [3]. The introduction of this series of policies has provided a clear direction and strong support for the application of distributed PV power generation in rural tourism.

2.2 High Environmental Adaptability

According to the data from the China Statistical Yearbook 2025, China's rural population in 2024 was 464.78 million, accounting for 33% of the total population. The per capita disposable income of rural residents in the eastern, central, western, and northeastern regions was RMB 28,646, RMB 21,799, RMB 19,147, and RMB 21,548, respectively. The total area of urban, rural, and industrial/mining land is 361,000 square kilometers [4]. In terms of energy consumption, rural energy is mainly derived from non-renewable fossil energy sources such as coal, and rural energy consumption is characterized by coarseness and dispersion, making rural areas one of the important sources of greenhouse gas emissions [5].

These data indicate that China has a large rural population, and per capita disposable income still has room for improvement. In terms of land area, rural areas possess ample open space, and the rooftops of rural residences remain underutilized. In addition, lighting conditions in most rural areas of China are stable, providing a favorable natural foundation for the development of PV power generation. Constructing distributed PV power generation systems in rural areas can, on one hand, make full use of idle open spaces and residential rooftops. On the other hand, it can help revitalize rural ecology and achieve the "dual carbon" goals through energy transformation. Moreover, besides meeting the collective and residential electricity needs, surplus electricity can be fed into the grid to increase farmers' income. Therefore, the construction of distributed PV power generation systems is highly suitable for the general rural development environment.

2.3 Strong Demonstration Effect

Rural rooftop distributed PV power generation systems exhibit strong technological replicability. They do not rely on complex customized designs or cutting-edge laboratory technologies. Instead, they should adopt standardized components that have been widely verified in the market, such as general-purpose monocrystalline silicon PV panels, modular lithium iron phosphate energy storage batteries, and smart inverters with MPPT functionality. These components can be flexibly scaled up or down according to different roof areas and electricity needs. A system scale of 20 kilowatts can be easily replicated in 10-kilowatt or 30-kilowatt scenarios. The installation and maintenance threshold is extremely low; ordinary electricians can perform daily inspections after simple training.

At the same time, the technical solution itself has a high degree of environmental adaptability. Whether in the plateaus of northern Shaanxi or the plains of Guanzhong, the core "PV + energy storage + power distribution" architecture requires no significant adjustments. Only fine-tuning of the tilt angle of PV panels according to local sunshine hours is needed. This characteristic of "design once, reuse in multiple locations" fundamentally ensures the replicability of the technology across different rural scenarios. In addition, PV projects are inherently economical. When technological replicability enables more people to follow suit at low cost and low risk, and the perceptibility of value allows everyone to see and feel the tangible benefits with their own eyes, PV projects are no longer isolated energy facilities but become a rural lifestyle that everyone aspires to adopt.

2.4 Outstanding Economic Benefits

According to the Measures for the Administration of Distributed Photovoltaic Power Generation Development and Construction, PV power generation can freely choose among three grid integration modes: full grid connection, full self-use, or self-use with surplus electricity fed into the grid. This provision allows rural collectives and farmers to rationally allocate the scale of power generation according to their own electricity needs and flexibly choose the most appropriate operation mode, thereby improving energy utilization efficiency and achieving greater economic benefits.

Hou Village in Zhaoqing City used 145 mu of idle shrimp ponds to develop a "PV + fishery" project. By collecting land rent and secondary "PV+" land rent, the project generated over RMB 1 million in income for the village's collective economy in 2023 [6]. In Danxian County, Heze City, the cooperation model of "farmer's rooftop + company operation and maintenance" involves enterprises investing in, installing, and maintaining PV systems under contract energy management, while farmers provide rooftop space in exchange for electricity revenue. Under this model, the budget for solar PV power generation projects in villages such as Rongzhuang Village, Zhaozhuang Village, and Yuanmiao Village in 2024 was approximately RMB 6.6 million [7].

The above are typical cases of distributed generation empowering rural economic benefits. In addition, across China's vast rural areas, many new models such as "agrivoltaics," "fishery-PV complementarity," and "herding-PV complementarity" are being continuously implemented. These models not only revitalize idle land, rooftops, and other stock resources but also generate stable and sustainable income for village collectives and farmers without affecting original agricultural production. They have opened new channels for increasing income, further activated the endogenous driving forces of rural economic development, accumulated funds for the development of rural industries, and laid a solid economic foundation for the subsequent development of rural tourism.

3. Application Scenarios of Rooftop Photovoltaic Power Generation Systems in Rural Tourism

3.1 Enhancing Homestay Accommodation Experience

Accommodation is often a key concern for tourists in any tourism scenario. In rural tourism, tourists' stereotypes about rural accommodation conditions and environments often influence their destination choices. In addition, transportation conditions, service quality, and hardware and software facilities are core bases for homestay pricing. Therefore, improving the quality of service supply and providing tourists with a comfortable accommodation experience are important components of the sustainable development of homestays.

Rooftop PV power generation systems can effectively solve accommodation problems caused by power bottlenecks. First, after connecting to a rooftop PV system, homestays can stably operate high-power electrical appliances such as central air conditioning, floor heating, and various household appliances, meeting tourists' demand for comfortable living quality. Second, the system can solve problems such as unstable power supply in summer and insufficient heating power in winter, ensuring the reliability of high service quality in rural homestays. Third, the economic income of homestays can be increased to some extent from the perspective of self-sufficiency in electricity consumption

and surplus electricity fed into the grid. Finally, charging piles can be installed to meet the charging needs of electric tourist vehicles and self-driving tourists, addressing the problem of insufficient supporting energy replenishment facilities in rural areas, thereby enhancing the attractiveness and service experience of homestays.

3.2 Improving the Service Quality of Farmhouse Dining

"Eating" is one of the six core elements of tourism services and an indispensable part of daily life. In travel reviews and route recommendations, a great deal of content related to "eating" can be found. Local specialties, in particular, often become an important factor influencing tourists' willingness to travel. In rural tourism, tourists often choose to eat in farmhouses because farmhouses are typically operated by local villagers in their own courtyards, offering a warm home atmosphere and local specialties.

Building a rooftop PV power generation system in farmhouses can effectively improve tourists' dining experience. Specifically, first, it can provide emergency energy storage and power supply. Voltage instability is frequent in rural areas. In the event of sudden power outages, PV power generation can supply electricity to farmhouses, ensuring the stable operation of catering equipment and policies. Second, it can help farmhouses achieve green cultivation. Natural ingredients are the core competitiveness of farmhouses. PV power generation provides a stable energy supply for vegetable garden irrigation, fish pond aeration, fruit and vegetable preservation, and other activities, ensuring the supply of fresh ingredients. Finally, it can help create nightscapes for farmhouses. Courtyard lighting, landscape light strips, signboard lights, and similar features can make the nighttime atmosphere of farmhouses more appealing, aligning with current aesthetic preferences.

3.3 Creating Rural Characteristic Landscapes

In the era of the experience economy, traditional sightseeing tourism projects are no longer attractive to new-generation tourists. As Generation Z gradually becomes the primary force in tourism consumption, tourists prefer immersive tourism projects with strong interactivity and rich experiences. Therefore, rural tourism urgently needs to be upgraded and to create more distinctive rural landscapes with the help of digital technology.

Rooftop PV power generation can provide energy supply for the digital transformation of rural tourism scenarios. First, PV modules can be integrated into the rural landscape as design elements. There are currently many practical cases in which PV modules are arranged in an artistic form or integrated into architectural design to form unique landscapes. Second, stable and sufficient electricity can support the creation of functional landscapes, such as new immersive interactive landscape facilities equipped with interactive lighting, unmanned services, virtual experiences, and other digital technologies, thereby enhancing the experience and attractiveness of rural tourism. Finally, rooftop PV systems can increase the supply of tourism content, especially in rural educational tourism. The rooftop distributed PV power generation system itself is an excellent theme and content, containing rich scientific knowledge and conveying the concept of ecological and environmental protection.

3.4 Incubating "PV + Tourism" Demonstration Projects

Attractiveness and experience are the core and goals of tourism project design. Creating a number of benchmark projects with high recognition and strong demonstration effects can effectively enhance the brand awareness of rural tourism and revitalize the rural economy. The "PV + tourism" model is a new industrial integration model that fits the sustainable development of rural areas in the context of rural energy reform. It can organically combine clean energy development with the development of rural tourism, drive the green transformation of rural tourism as a whole, and broaden the income channels for rural collective economies and farmers.

First, localities can develop characteristic "PV + tourism" projects according to their own resource conditions and local circumstances, effectively leveraging resource endowments to achieve integrated development-such as "PV + hot spring," "PV + healthcare," and "PV + agricultural experience."

Second, they can shape their own "PV + tourism" brand, leveraging brand effects to promote the sustainable development of local rural tourism. Finally, typical "PV + tourism" projects can be created, successful and replicable development and operation experiences can be summarized, a point-to-area development trend can be formed, and the "PV + tourism" model can be promoted to take root in the field of rural tourism, benefit thousands of households, and support the implementation of rural prosperity strategies.

4. Technical Scheme of Rural Roof Photovoltaic Systems

Due to the inability of large-scale interconnected power systems to flexibly track load changes and their proneness to failure, the combination of large-scale power grids and distributed power generation is recognized by the global energy and power sectors as the main way to save investment, reduce energy consumption, and improve the reliability and flexibility of power systems [8]. PV power generation systems are generally divided into two types. One is the centralized PV power generation system, which mainly involves large ground-mounted power stations of over a dozen megawatts on vast land areas. The other is the distributed PV power generation system, which is typically megawatt-level or below and installed on various rooftops [9].

According to collaborative research by Tsinghua University and the Land Satellite Remote Sensing Application Center of the Ministry of Natural Resources of China, in 2020, the roof area of rural buildings in China was approximately 27.33 billion square meters. It is estimated that 13.1 billion square meters of PV panels can be installed on rural roofs, and the total installable PV scale on rural roofs nationwide would reach 1.97 billion kW, with an annual power generation of 2.95 trillion kWh [10]. Therefore, building rooftop distributed PV power generation systems in rural areas is feasible and of great significance.

In terms of technical schemes, rural rooftop PV power generation systems are generally divided into grid-connected and off-grid systems. Grid-connected systems are mainly composed of AC distribution boxes, inverters, DC distribution boxes, and other grid-connected equipment such as battery arrays. Off-grid systems are mainly composed of DC boxes, solar cell arrays, reverse transformers, and energy-saving devices [11]. Because off-grid systems require large-capacity energy storage equipment to ensure the stability of power output, their overall construction and maintenance costs are high. In contrast, grid-connected PV systems can be directly connected to the public power grid, relying on the grid for peak adjustment to balance power generation fluctuations. At the same time, surplus power can be sold online, making grid-connected schemes adaptable to most rural rooftop applications. Therefore, at present, rural rooftop distributed PV power generation mostly adopts grid-connected technical schemes.

The working principle of a grid-connected PV power generation system is as follows: direct current generated by the solar cell array under sunlight flows into the DC distribution cabinet via the junction box, then connects to the grid-connected inverter, where it is converted to alternating current output, and then stepped up by a step-up transformer before connecting to the external grid. The operation of each device is monitored and recorded by a communication system. The system configuration is shown in Figure 1 [12].

In rural tourism, rooftop PV power generation systems generally include household units, represented by homestays and farmhouses, and village collective units, represented by PV landscapes and "PV + tourism" projects. The main high-power equipment in household units includes central air conditioning, televisions, computers, water heaters, water pumps, freezers, and charging piles, with an average daily electricity consumption of about 30 kWh. The average daily effective sunlight hours in Xi'an, Shaanxi Province, in 2020 was 4.80 hours. Taking a farmhouse in Xi'an as an example, to ensure normal operation, it is necessary to install a 20 kW PV system with 150 kWh energy storage and a 25 kW inverter. With 20 kW of PV panels, the annual power generation per household exceeds 20,000 kWh. The 150 kWh energy storage configuration can meet electricity demand for two

consecutive rainy days. The rooftop PV power generation system for a household unit is shown in Figure 2.

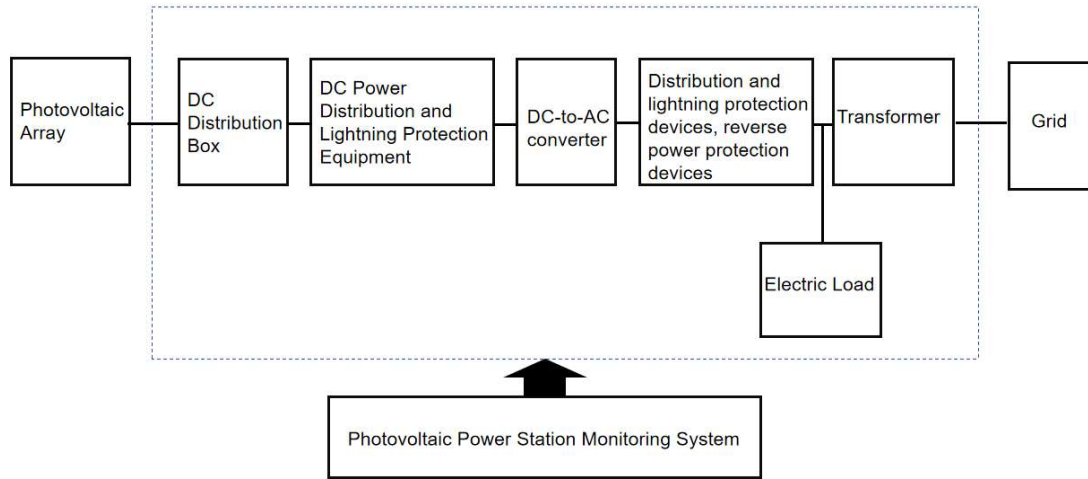

Figure 1. Grid-connected Photovoltaic Power Station System Configuration Diagram

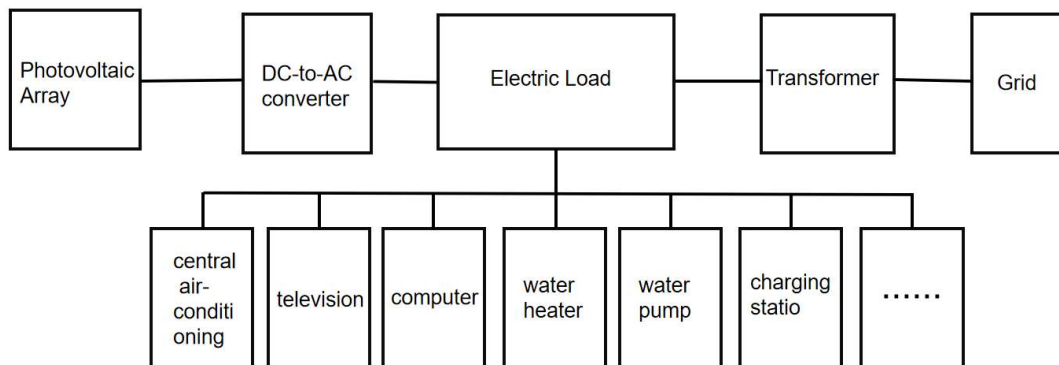

Figure 2. The Rooftop Photovoltaic Power Generation System for Residential Unit

Village collective units mainly arrange PV power generation systems on idle sites or continuous roofs of public buildings in the village. The installation scale is larger, and it is easier to form centralized continuous PV power stations. After connecting energy storage devices of appropriate capacity, these systems can not only meet the daily electricity needs of village tourist centers, public parking lot lighting, cultural tourism reception places, and other idle public facilities but also feed surplus electricity into the grid to obtain power generation income.

In actual project planning, there are many typical cases. For example, the rural landscape PV power generation system represented by the desert PV landscape in Zhongwei, Ningxia, covers nearly 30,000 mu and comprises more than 2.2 million PV panels. Each array adopts a single-axis tracking bracket. Through a control system, the PV modules can present three color changes (dark blue, red, and sand yellow) at different tilt angles, displaying complex patterns and text like a page-turning billboard for corporate publicity or commercial advertising space rental. The annual power generation capacity of the first phase of the project is 1.8 billion kWh, which innovates desert construction technology and has become a beautiful tourist attraction in the Zhongwei area [13].

Another example is the "PV + agriculture" project represented by the 200-megawatt agrivoltaic project in Zhenfeng County, Guizhou. The total installed capacity is 200 megawatts, covering a total

land area of 268.21 hectares. The project uses PERC monocrystalline silicon PV cell modules with a tilt angle of 20° and adopts string inverters. The completed PV power station is connected to the newly built 220 kV booster station of Huadian Beipanjiang via eight 35 kV collector lines, and then transfers power to the 500 kV booster station in Renyi, effectively promoting the deep integration of "PV + rural revitalization" [14].

5. Conclusion

This study discusses the feasibility of promoting rural energy transformation and rural tourism to support rural revitalization through the construction of rooftop distributed PV power generation systems in rural areas under the background of rural revitalization. On one hand, the construction of rooftop distributed PV power generation systems can provide sustainable clean energy for rural areas, achieving ecological protection and electricity security. On the other hand, surplus electricity can be fed into the grid, further increasing the actual income of village collectives and farmers. From the perspective of rural tourism, rooftop distributed PV power generation systems can promote the upgrading of rural tourism in four aspects: enhancing homestay accommodation experience, improving farmhouse dining service quality, creating rural characteristic landscapes, and incubating typical "PV + tourism" projects.

At the level of technical realization, the construction plan for rooftop distributed PV power generation systems can be discussed from both household units and village collective units. Household units should focus on the electricity demand of appliances, energy storage requirements for continuous weather conditions, and the problem of surplus electricity feed-in. Village collective units need to focus on the typicality and representativeness of projects. This study concentrates on the application of rural rooftop distributed PV power generation systems in rural tourism, analyzes the application value and practical pathways of this model, and provides a reference for sustainable rural development.

References

- [1] Jiang, Y., & Hu, S. (2022). Research on the development strategy of production and consumption integrated rooftop PV system in rural China. *Climate Change Research*, 18(3), 272–282.
- [2] Zhan, T. J., & Xie, Y. R. (2021). Development status analysis and consideration on domestic distributed PV energy. *Huadian Technology*, 43(12), 60–65.
- [3] Sanqin.com. (2024, August 22). Shaanxi launches the 'PV+' demonstration project for rural revitalization in thousands of villages and households, accelerating the development of distributed photovoltaic [Web page]. Retrieved April 10, 2026, from https://www.sanqin.com/2024-08/22/content_10824244.html
- [4] National Bureau of Statistics of China. (2025). *China statistical yearbook*. China Statistics Press.
- [5] Dou, C., Zuo, C., Jia, Y., et al. (2023). Analysis on development potential of rooftop distributed PV power generation of rural residential dwellings in China. *Solar Energy*, (1), 5–16.
- [6] Zhang, Y. H., & Wu, H. J. (2024, August 13). Awaken "dormant assets" and enjoy "passive income" [Newspaper article]. *Xijiang Daily*, p. 1.
- [7] Cheng, L., Jiang, L. Y., & Shi, X. B. (2025). Practical pathways for distributed photovoltaic power generation in Shandong Province to contribute to achievement of "dual carbon" goals. *Energy and Energy Conservation*, (S1), 1–6.
- [8] Liang, C. H., & Duan, X. Z. (2001). Distributed generation and its impact on power systems. *Automation of Electric Power Systems*, (12), 53–56.
- [9] Wang, W. J., & Wang, S. C. (2016). Status and prospect of Chinese distributed photovoltaic power generation system. *Bulletin of Chinese Academy of Sciences*, 31(2), 165–172.
- [10] Jiang, Y., & Hu, S. (2022). Research on the development strategy of production and consumption integrated rooftop PV system in rural China. *Climate Change Research*, 18(3), 272–282.
- [11] Li, Y. (2016). Discussion on the technical solutions for distributed photovoltaic power generation systems installed on rooftops. *Low Carbon World*, (26), 46–47.

- [12]Jiang, L. (2018). Investigation on application of rooftop grid-connected distributed photovoltaic generation technology scheme. *Electric Engineering*, (11), 139–141.
- [13]Qin, R. J. (2025, February 11). A comprehensive benefit analysis of the new energy base in desert areas, the Gobi, and other arid [Newspaper article]. *People's Daily*, p. 8.
- [14]Zhang, M. F. (2026). Research on design and key technologies of photovoltaic power generation system for agricultural photovoltaic power station in Guizhou mountainous areas. *Mechanical & Electrical Technique of Hydropower Station*, 49(4), 101–105, 110.